

Fig. 1a

Jøtul FS 165 - I 200 FL

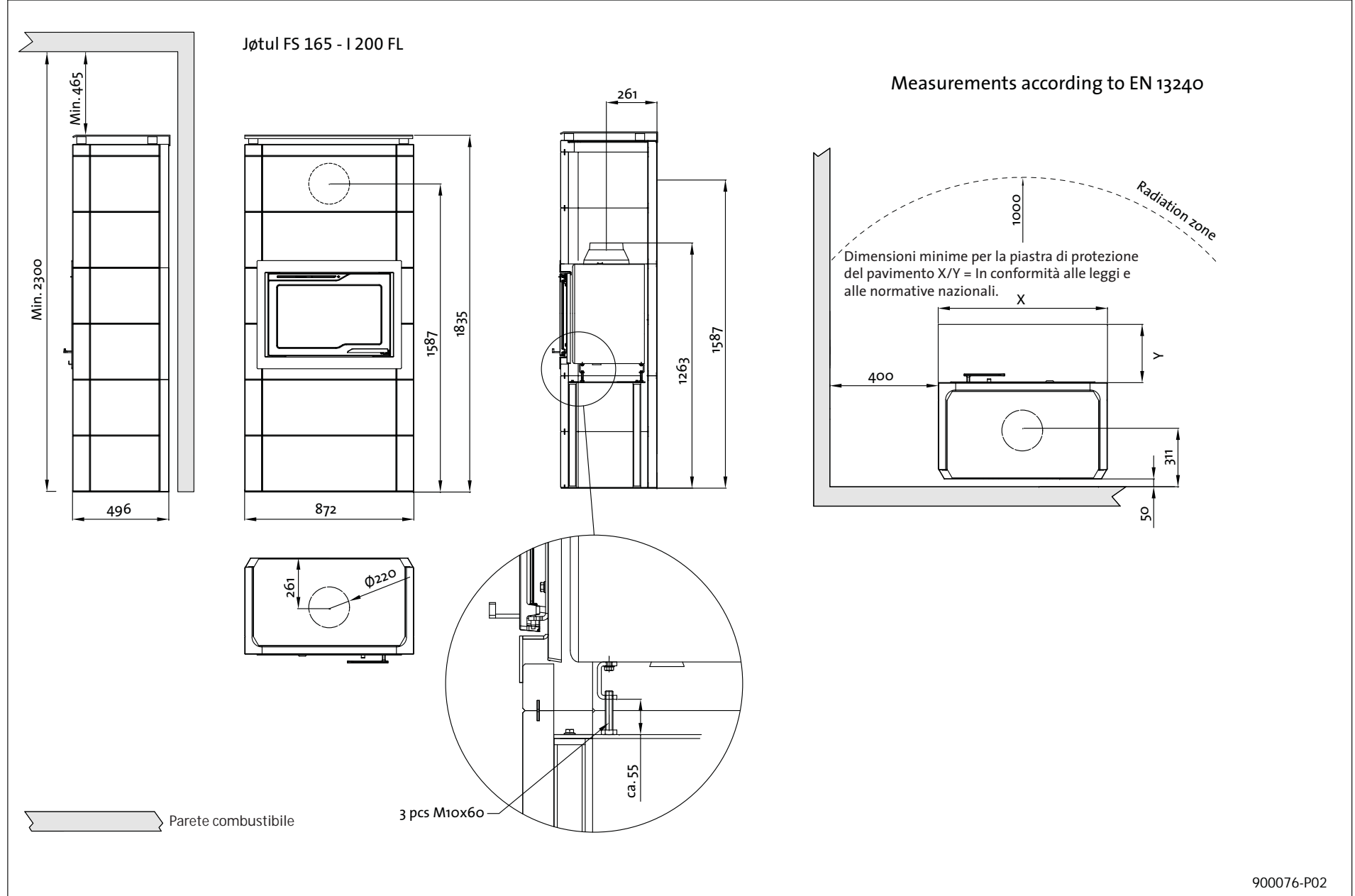

Fig. 1b

Jøtul FS 165 - I 500 FL / I 530 FL

